

NOTE: ARMREST STYLES
 WHEN ORDERING ARMRESTS, PLEASE
 CHECK THAT PARTS REQUIRED ARE
 THE SAME STYLE AS THOSE PICTURED.
 IF THEY DIFFER, CONTACT MEDICARE
 TECHNOLOGY

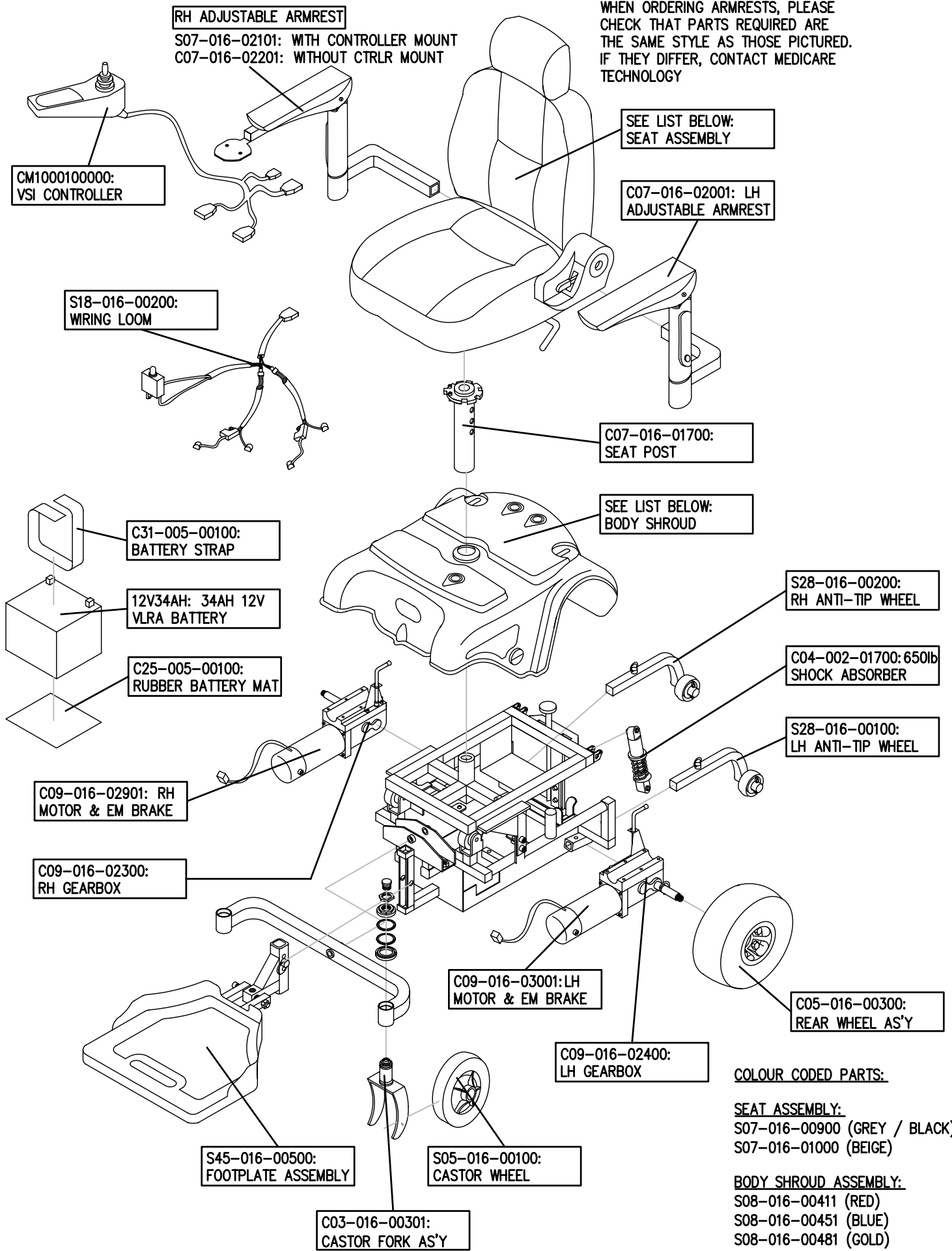

COLOUR CODED PARTS:

SEAT ASSEMBLY:
 S07-016-00900 (GREY / BLACK)
 S07-016-01000 (BEIGE)

BODY SHROUD ASSEMBLY:
 S08-016-00411 (RED)
 S08-016-00451 (BLUE)
 S08-016-00481 (GOLD)